

64X33X51-S3-2.0



AUSTROFLAMM



www.austroflamm.com

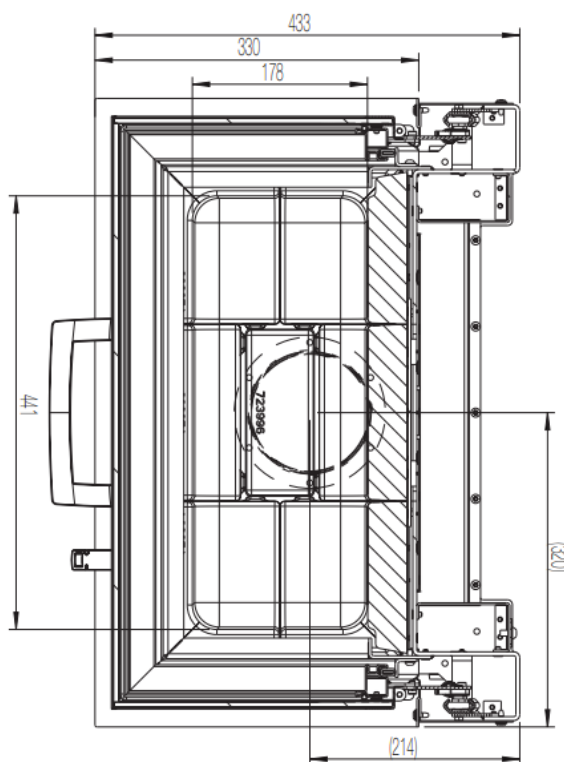
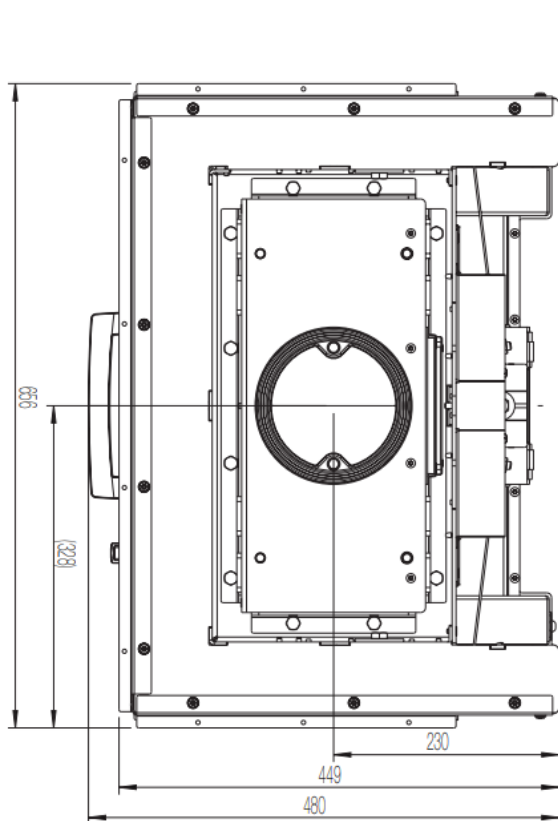
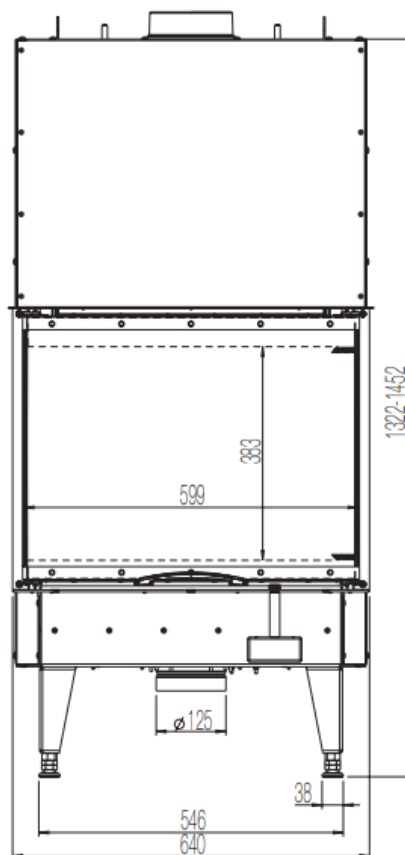
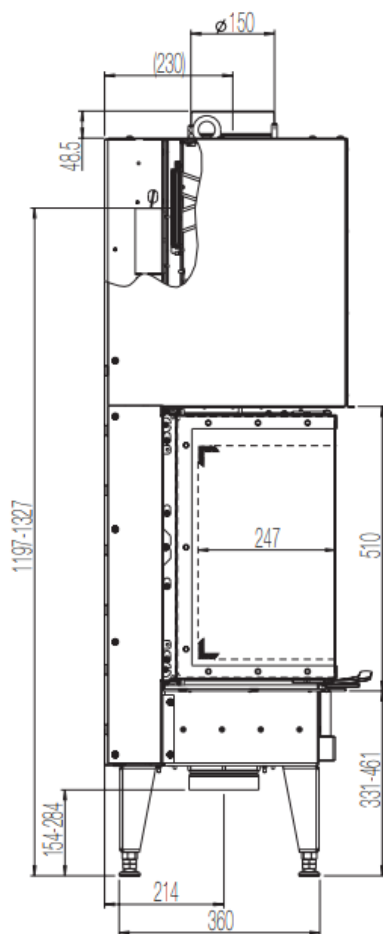

o standard

Z Accessories

- not available

| DIMENSIONS AND WEIGHTS | |
|---|-----------|
| Height [mm] | 1371-1509 |
| Width [mm] | 656 |
| Depth [mm] | 449 |
| Weight [kg] | 199 |
| Width (body installation dimension) [mm] | 640 |
| Door frame, height [mm] | 510 |
| Flue pipe outlet, diameter [mm] | 150 |
| Insulation layer thicknesses to the installation floor [mm] (Promasil 950 KS) | 0 |
| Insulation layer thicknesses lateral / rear [mm] (Promasil 950 KS) | 0/60 |
| Insulation layer thicknesses to the ceiling [mm] (Promasil 950 KS) | 120 |
| Ceramic flues - max. length [m] | x |
| HEAT OUTPUT | |
| Nominal heat efficiency [kW] lt. EN test EN 13229 | 10 |
| Heat output, minimum [kW] / Maximum heat output [kW] | 5-14 |
| Energy efficiency category | A |
| Circulating air cross-section without / with metal secondary heating surface [cm ²] | 700 |
| FEATURES | |
| Double pane | x |
| Sliding door | yes |
| DATA FOR THE CHIMNEY SWEEP | |
| Total flue gas flow [g/s] | 11.86 |
| Flue gas temperature [°C] | 261 |
| Minimum feed pressure at nominal heat efficiency [Pa] | 12 |