

PERCY

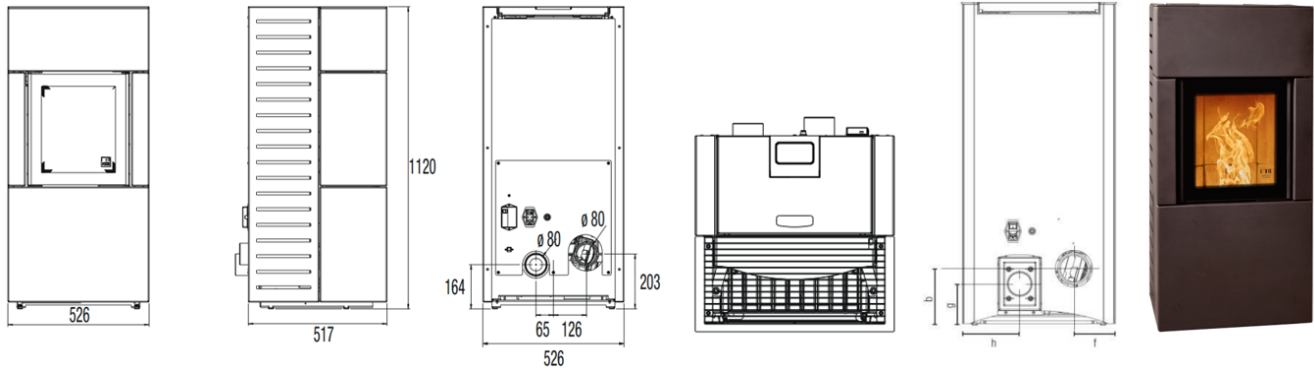

www.austroflamm.com



DIMENSIONS AND WEIGHTS

Height [mm]	1120
Width [mm]	526
Depth [mm]	517
Flue outlet diameter [mm]	80
External air connection [Ø mm]	80
Weight [kg]	181
b: Connection height with flue rear [mm]	203
f: Flue connection from right [mm]	137
g: Connection heat external air [mm]	164
h: External air connection from left [mm]	198

HEAT OUTPUT

Nominal heat efficiency [kW] lt. EN 13240	8.0
Min. / max. heat output [kW]	2.4-8.6
Min/max space heating capacity [m³]	114-305
Pellet hopper [kg/l]	≈ 25/39
Min / max fuel consumption [kg/h]	0.6-2.10
Min / max burning time [h]	12-42

FEATURES

Room thermostat	o
(Weekly) timer	o
Automatic grate	o
Independent of ambient air	o
Power connection [V/Hz]	230/50
WLAN	Z
Remote control	o
Convection module	-

DATA FOR THE CHIMNEY SWEEP

Total flue gas flow [g/s] closed	6.13
Flue gas temperature [°C] closed	208
Minimum feed pressure at nominal heat efficiency [Pa] closed	12
Minimum feed pressure for chimney calculation [Pa]	3