

ELECTRIC DIAGRAM: MAIN

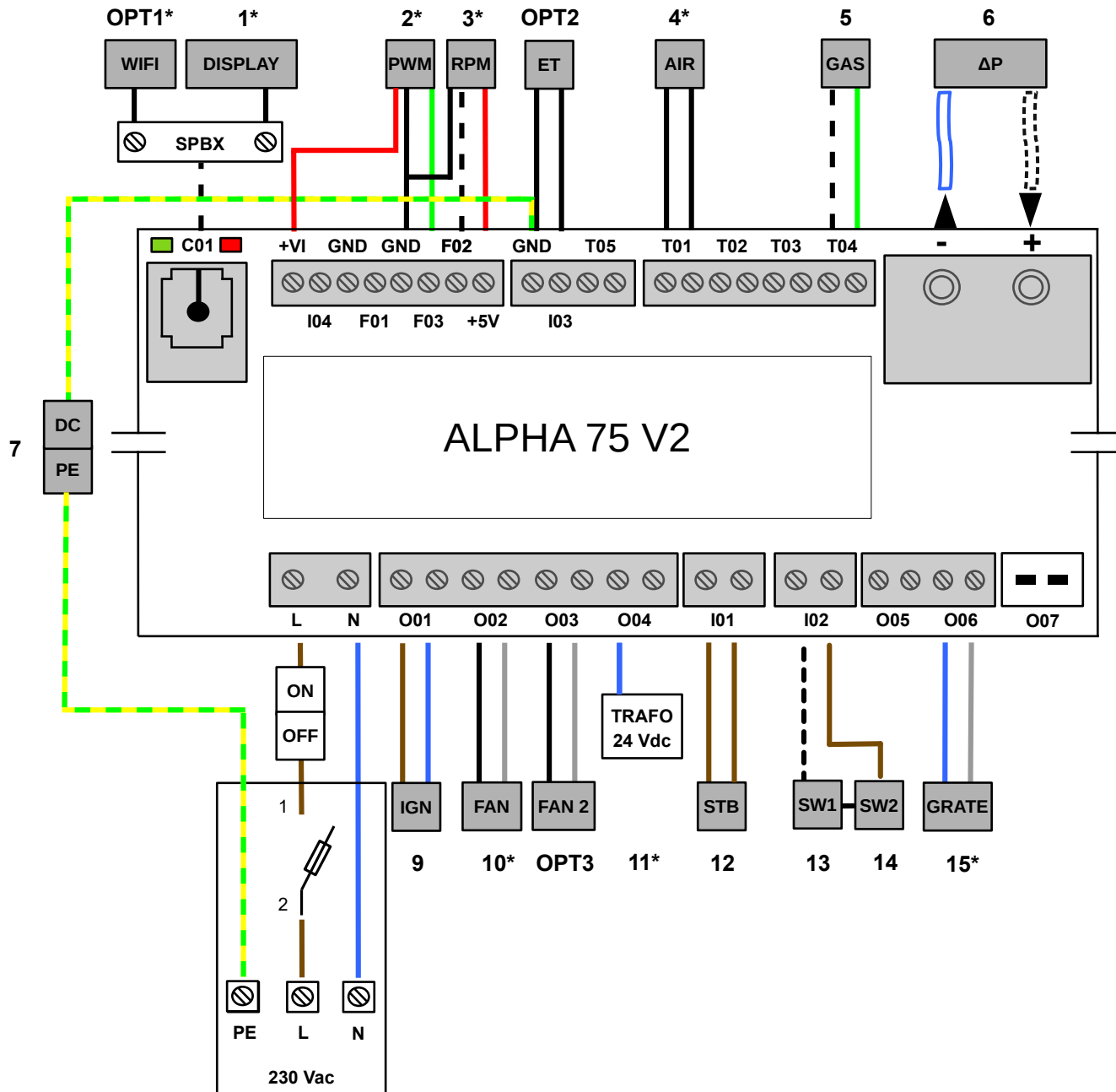

1.	Display
2.	PWM to DC Converter
3.	RPM / HAL-IC
4.	Room temperature sensor
5.	Firebox temperature sensor
6.	Differential pressure measurement
7.	Central grounding
8.	Controller grounding
9.	Ceramic ignition
10.	Combustion fan
11.	24V trafo
12.	Safety temperature limiter
13.	Hopper lid safety switch
14	Grate position switch
15	Grate motor
OPT1	WiFi module
OPT2	External thermostat
OPT3	Air distribution module
★	See additional electric wiring diagrams

ELECTRIC DIAGRAM: COMBUSTION VENTILATOR

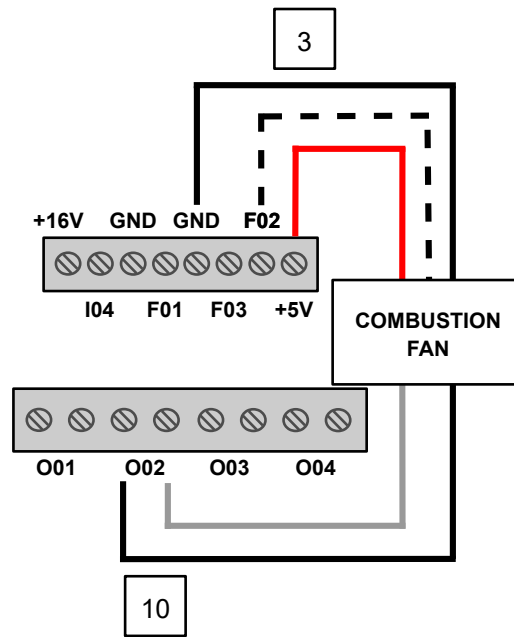

ELECTRIC DIAGRAM: FEEDER MOTOR

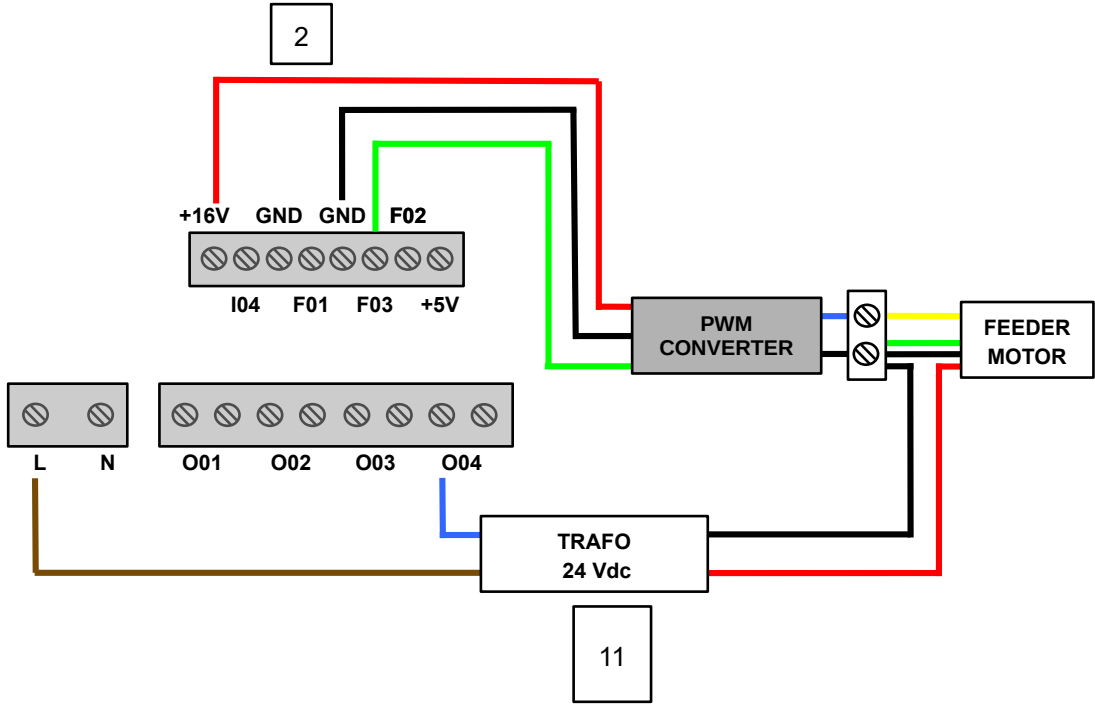

ELECTRIC DIAGRAM: GRATE MOTOR

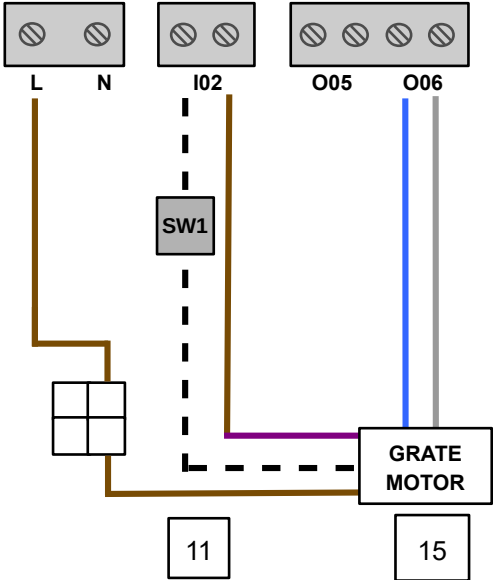

ELECTRIC DIAGRAM: COMMUNICATION SPLITTER

