

48X51X51-S3-2.0



[www.austroflamm.com](http://www.austroflamm.com)

# 48X51X51-S3-2.0



AUSTROFLAMM

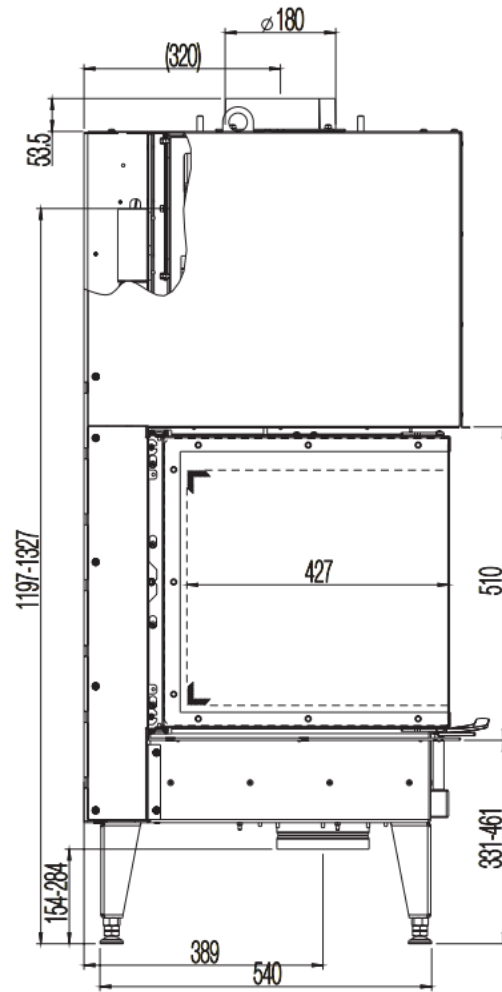
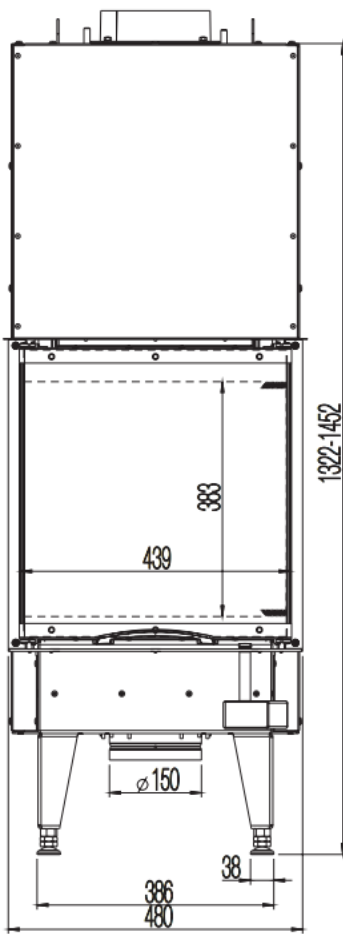

o standard

Z Accessories

- not available

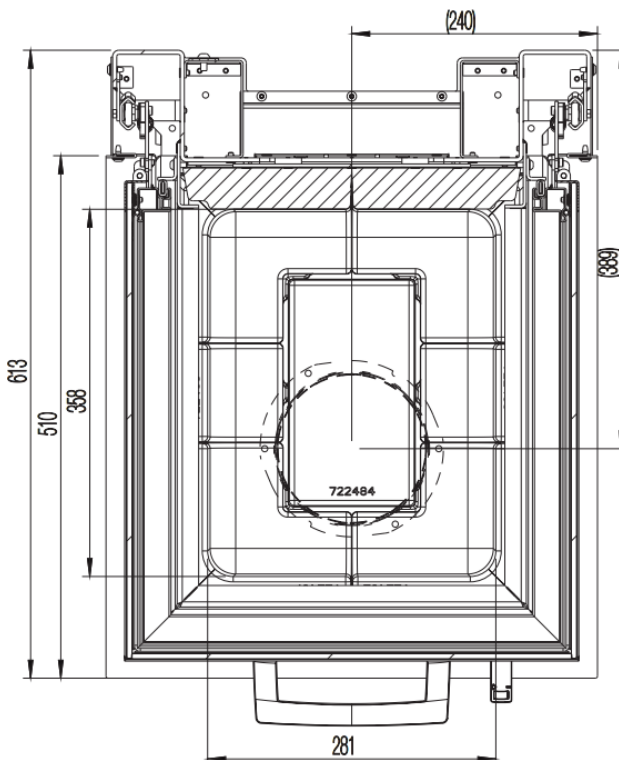
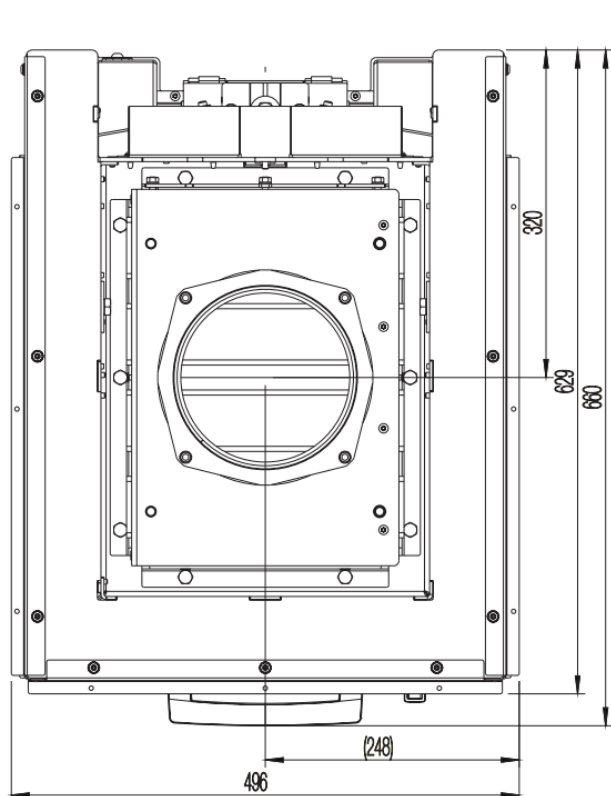

## DIMENSIONS AND WEIGHTS

Height [mm]	1376-1514
Width [mm]	496
Depth [mm]	629
Weight [kg]	202
Width (body installation dimension) [mm]	480
Door frame height [mm]	510
Flue outlet diameter [mm]	180
Insulation layer thicknesses to the installation floor [mm] (Promasil 950 KS)	0
Insulation layer thicknesses lateral / rear [mm] (Promasil 950 KS)	0/60
Insulation layer thicknesses to the ceiling [mm] (Promasil 950 KS)	120
Ceramic flues - max. length [m]	x

## HEAT OUTPUT

Nominal heat efficiency [kW] lt. EN test EN 13229	10
Minimum heat output [kW] / Maximum heat output [kW]	5-14
Energy efficiency category	A+
Circulating air cross-section without / with metal secondary heating surface [cm <sup>2</sup> ]	710

## FEATURES

Sliding door	yes
Double pane	x

## DATA FOR THE CHIMNEY SWEEP

Total flue gas flow [g/s]	11.96
Flue gas temperature [°C]	231
Minimum feed pressure at nominal heat efficiency [Pa]	12